

TEMPERATURE CONTROLLER

OPERATION MANUAL

Before using please check whether range, input and output match your requirement.

Thank you for using our microprocessor temperature controller, we have obtained CSA approved NO LR # Mark HCS 519 686 2715. We have also computerized our QC process and testing to provide high quality standard, low price and high functionality in our products.

1. Front panel instruction

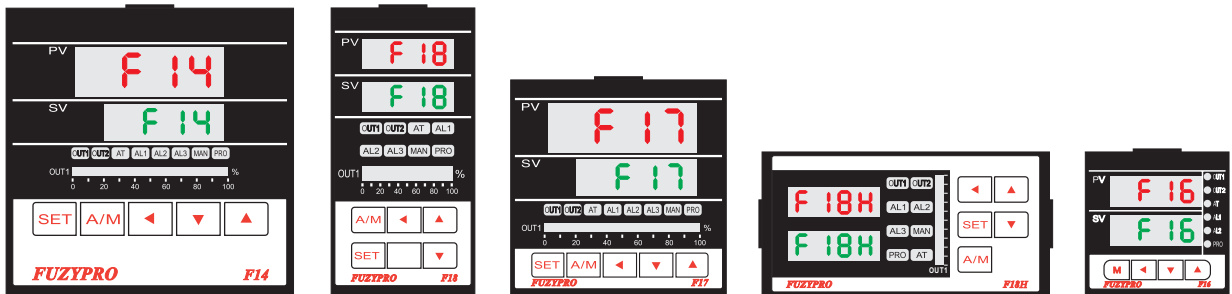

1.1 DISPLAY

PV : Process value , 4 digit display (red color)
 SV : Setting value , 4 digit display (green color)

1.2 LED

OUT1 : Output 1 , green color
 OUT2 : Output 2 , green color
 AT : Auto Tuning , yellow color
 PRO : Program , yellow color
 AL1 : Alarm 1 , red color
 AL2 : Alarm 2 , red color
 AL3 : Alarm 3 , red color
 MAN : Manual , yellow color

*Note: When error occurs, the MAN will light up, and will reset output percentage to zero.

1.3 KEY

SET : MODE & SET key

◀ : SHIFT key

▽ : DOWN key (Setting value -1, -10, -100, -1000)

△ : UP key (Setting value +1, +10, +100, +1000)

A/M : Auto/Manual key.

Automatic : The output percentage is determined by internal calculation.

Manually : The output percentage is determined by manually set OUTL at User Level.

2 Auto tuning

2.2 Once AT is set YES , auto tuning is to be performed.

2.3 After auto tuning is finished , a new set of PID parameter is generated internally to replace the existing PID parameter.
* Auto tuning allows the controller to automatically adjust the PID parameter, and is suitable for use when temperature control is not accurate enough.

2.4 $ATVL = \text{auto tuning offset}$, and it will be deduced from SV
(it can prevent over shoot during auto tuning)
 $SV - ATVL = \text{Auto-tuning value}$, $ATVL = \text{auto tuning offset}$
Ex. $SV = 200^{\circ}\text{C}$, $ATVL = 5$, Auto tuning point is at 195°C .
During auto tuning the PV value will oscillate around 195°C .
Hence PV will not go over 200°C .

* In programmable model , ATVL means Auto-tuning point

2.5 Auto tuning failure

Possible Cause 1 : ATVL is too big. (If not sure , set $ATVL = 0$)

Possible Cause 2 : System time is too long.

(Set PID parameter individually)

3. Error information

DISPLAY	DESCRIPTION
IN1E	Open circuit of main control sensor.
* ADCF	A/D converter failed.
* CJCE	Cold junction compensation failed.
IN2E	Open circuit of sub control sensor.
UUU1	PV exceeds USPL.
NNN1	PV under LSPL.
UUU2	Input signal of sub control exceeds the upper limit.
NNN2	Input signal of sub control under the lower limit.
* RAMF	RAM failed.
INTF	Interface failed.
AUTF	Auto tuning failed.

NOTE : If the “*” marked error comes up , the Controller needs repair.
Please send it to the nearest sales office or retail dealer.

4. Operating flow

4.1 LEVEL 1 (User Level)

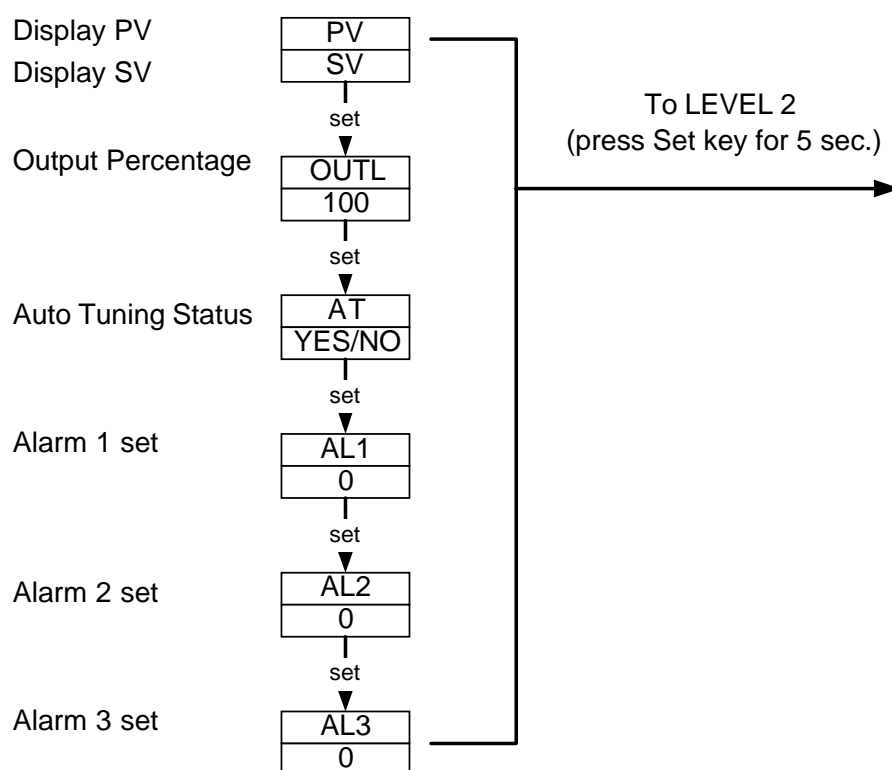

- 4.1.1 Press the **SHIFT KEY** (◀) to change the parameters. If the **SHIFT KEY** is pressed, the first digit begins blinking. Press the **UP KEY** (▲) or **DOWN KEY** (▼) to increase or decrease the value of the digit, then press the **SHIFT KEY** (◀) again to go to the next digit. As all the digit are written, press **SET KEY** to enter the value.
- 4.1.2 **SET KEY** also has the function of changing MODEs, if the **SET KEY** is pressed, the display shows the next MODE.
- 4.1.3 Press **SET KEY** for 5 sec. the display goes to LEVEL 2, and do the same to return LEVEL 1.
- 4.1.4 If any key were not pressed for 1 minute, the display would go to LEVEL 1.
- 4.1.5 Press **A/M KEY** twice will go to LEVEL 1, no matter where it is.
- 4.1.6 If **OUTL** set "0", it means the controller has no output,

4.2 LEVEL 2 (PID Level)

press SET key for 5 seconds to enter Level 2

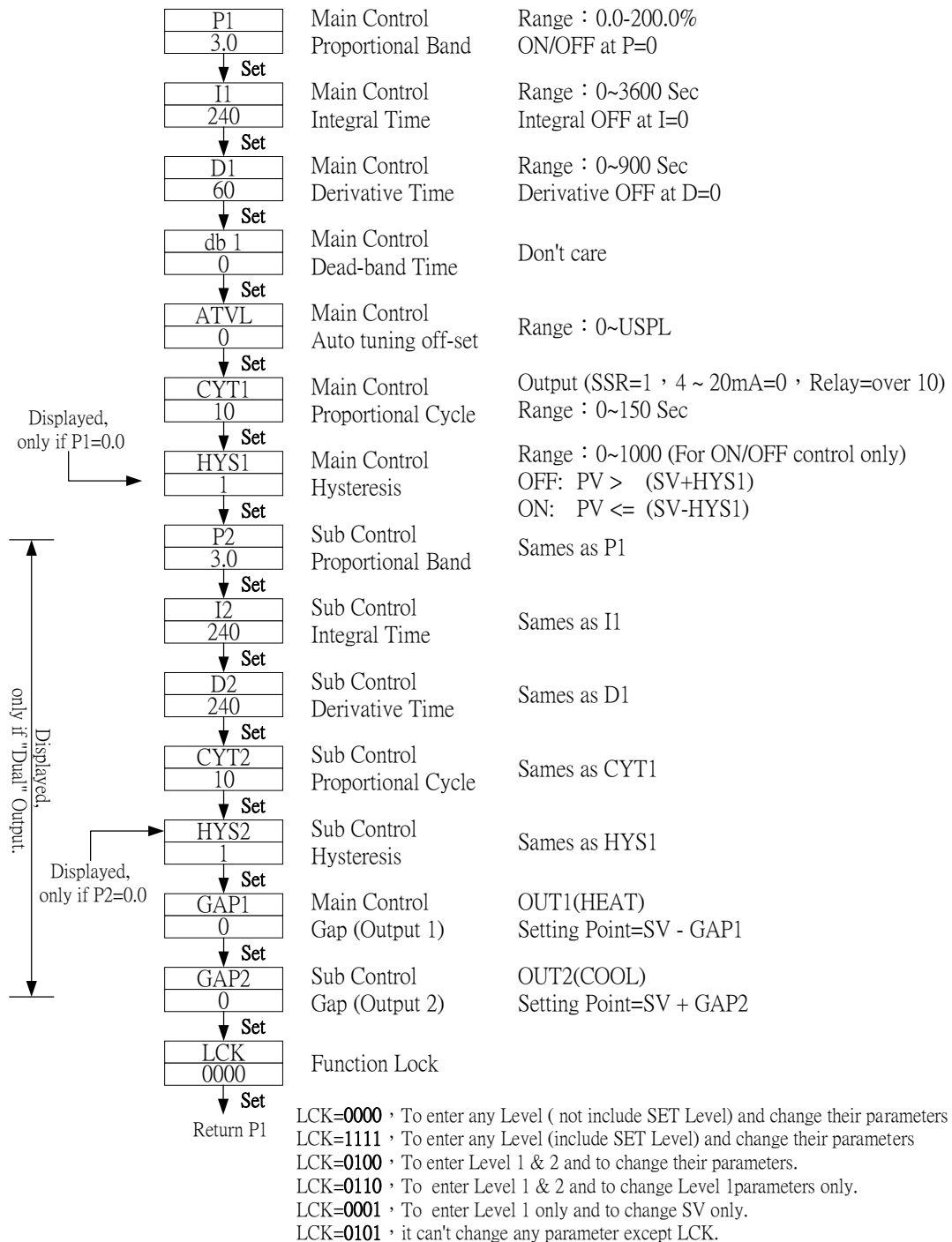

4.3 LEVEL 3 (INPUT Level)

When LCK=0000 , press SET key and SHIFT KEY  for 5 seconds to enter

LEVEL 3

INP1 K2	Main Control input selection	select the input range , refer to input selection (P.12 ~ 13)
↓ Set		
ANL1 0	Main Control Analog Zero set	It is used when INP1=AN1~AN5 Range : -1999 ~ 9999
↓ Set		
ANH1 5000	Main Control Analog Span set	Range : 0 ~ 9999
↓ Set		
DP 0000	Decimal point	To set the position of decimal point (Only applicable when INP1=AN1~AN5)
↓ Set		
LSPL 0.0	Lower set-point limit	To set the lowest point within INP1
↓ Set		
USPL 400.0	Upper set-point limit	To set the highest point within INP1
↓ Set		
ANL2 0	Sub Control Analog Zero set	Range : -1999 ~ 9999
↓ Set		
ANH2 5000	Sub Control Analog Span set	Range : 0 ~ 9999
↓ Set		
ALD1 01	Alarm mode of AL1	Range:00~19 (see P.14~15)
↓ Set		
ALT1 10	Time set of Alarm 1	Range : 0~99.59 min. 0=flicker alarm , 99.59=continued , and other=on delay time Note:In program model,ALT=Alarm on time
↓ Set		
ALD2 01	Alarm mode of AL2	Range:00~19 (see P.14~15)
↓ Set		
ALT2 0	Time set of Alarm 2	Sames as ALT1
↓ Set		
ALD3 01	Alarm mode of AL3	Range:00~19 (see P.14~15)
↓ Set		
ALT3 0	Alarm 3 time set	Sames as ALT1
↓ Set		
HYSA 0	Hysteresis of alarm	Range : 0~1000
↓ Set		
CLO1 230	Main Control calibration	Calibrate the low value of output Range : 0 ~ 9999(current output only)
↓ Set		

CHO1 3600	Main Control Calibration high	To calibrate the high value of output Range:0~9999(current output only)
↓ Set		
CLO2 230	Sub control Calibration low	Same as CLO1
↓ Set		
CHO2 3600	Sub control Calibration high	Same as CHO1
↓ Set		
CLO3 0	Transmitter control Calibration low	Same as CLO1
↓ Set		
CHO3 5000	Transmitter control Calibration high	Same as CHO1
↓ Set		
RUCY 5	Timer of motor	Full run time of proportional motor (without potentiometer) Range : 5~200 sec.
↓ Set		
WAIT 0	Use in program for waiting continued operation	0=No Wait Other=Wait volume
↓ Set		
SETA 0000		Refer to "SETA" description. (see P.22)
↓ Set		
IDNO 1	ID number (don't care)	Communication ID number
↓ Set		
BAUD 2400	Baud rate (don't care)	UART baud rate selection Range : 110~9600 BIT/sec
↓ Set		
SVOS 0	Compensate SV	Range : -1000~1000
↓ Set		
PVOS 0	Compensate PV	Range : LSPL~USPL
↓ Set		
UNIT C	Unit of PV & SV	Range : C , F , A(analog)
↓ Set		
SOFT 0.200	Soft filter (don't care)	Adjust the response time of PV (the bigger , the faster) Range : 0.05~1.00
↓ Set		
CASC	don't care	
↓ Set		
OUD HEAT	Action mode	Range : heat , cool
↓ Set		
OPAD PID	Control action	Range : PID , Fuzzy
↓ Set		
HZ 60	Frequency	Range : 50 , 60HZ
↓ Set		
Return INP1		

5. INPUT

5.1 Input selection (INP1)

<i>TYPE</i>	<i>CODE</i>	<i>RANGE</i>
K	K1	0.0 ~ 200.0°C / 0.0 ~392.0°F
	K2	0.0 ~ 400.0°C / 0.0 ~752.0°F
	K3	0 ~ 600°C / 0 ~1112°F
	K4	0 ~ 800°C / 0 ~1472°F
	K5	0 ~ 1000°C / 0 ~1832°F
	K6	0 ~ 1200°C / 0 ~2192°F
J	J1	0.0 ~ 200.0°C / 0.0 ~392.0°F
	J2	0.0 ~ 400.0°C / 0.0 ~752.0°F
	J3	0 ~ 600°C / 0 ~1112°F
	J4	0 ~ 800°C / 0 ~1472°F
	J5	0 ~ 1000°C / 0 ~1832°F
	J6	0 ~ 1200°C / 0 ~2192°F
R	R1	0 ~ 1600°C / 0 ~2912°F
	R2	0 ~ 1769°C / 0 ~3216°F
S	S1	0 ~ 1600°C / 0 ~2912°F
	S2	0 ~ 1769°C / 0 ~3216°F
B	B1	0 ~ 1820°C / 0 ~3308°F
E	E1	0 ~ 800°C / 0 ~1472°F
	E2	0 ~ 1000°C / 0 ~1832°F
N	N1	0 ~ 1200°C / 0 ~2192°F
	N2	0 ~ 1300°C / 0 ~2372°F
T	T1	0.0 ~ 400.0°C / 0.0 ~752.0°F
	T2	0.0~ 200.0°C / 0.0 ~392.0°F
	T3	0.0 ~ 350.0°C / 0.0 ~662.0°F
W	W1	0 ~ 2000°C / 0 ~3632°F
	W1	0 ~ 2320°C / 0 ~2372°F
PL II	PL 1	0 ~ 1300°C / 0 ~2372°F
	PL 2	0 ~ 1390°C / 0 ~2534°F
U	U1	-199.9 ~ 600.0°C / -199.9 ~999.9°F
	U2	-199.9 ~ 200.0°C / -199.9 ~392.0°F
	U3	0.0 ~ 400.0°C / 0.0 ~752.0°F

TYPE	CODE	RANGE
L	L1	0 ~ 400°C / 0 ~ 752°F
	L2	0 ~ 800°C / 0 ~ 1472°F
JIS PT100	JP 1	-199.9 ~ 600.0°C / -199.9 ~ 999.9°F
	JP 2	-199.9 ~ 400.0°C / -199.9 ~ 752.0°F
	JP 3	-199.9 ~ 200.0°C / -199.9 ~ 392.0°F
	JP 4	0 ~ 200°C / 0 ~ 392°F
	JP 5	0 ~ 400°C / 0 ~ 752°F
	JP 6	0 ~ 600°C / 0 ~ 1112°F
DIN PT100	DP 1	-199.9 ~ 600.0°C / -199.9 ~ 999.9°F
	DP 2	-199.9 ~ 400.0°C / -199.9 ~ 752.0°F
	DP 3	-199.9 ~ 200.0°C / -199.9 ~ 392.0°F
	DP 4	0 ~ 200°C / 0 ~ 392°F
	DP 5	0 ~ 400°C / 0 ~ 752°F
	DP 6	0 ~ 600°C / 0 ~ 1112°F
JIS PT50	JP.1	-199.9 ~ 600.0°C / -199.9 ~ 999.9°F
	JP.2	-199.9 ~ 400.0°C / -199.9 ~ 752.0°F
	JP.3	-199.9 ~ 200.0°C / -199.9 ~ 392.0°F
	JP.4	0 ~ 200°C / 0 ~ 392°F
	JP.5	0 ~ 400°C / 0 ~ 752°F
	JP.6	0 ~ 600°C / 0 ~ 1112°F
AN1	AN1	-10 ~ 10mV / -1999~9999
AN2	AN2	0 ~ 10mV / -1999~9999
AN3	AN3	0 ~ 20mV / -1999~9999
AN4	AN4	0 ~ 50mV / -1999~9999
AN5	AN5	10 ~ 50mV / -1999~9999

* The initial set in factory is "K2" without any certain requirement

6. ALARM

6.1 Alarm function selection









CODE	DESCRIPTION	INHIBIT
00 / 10	None	
01	Deviation high limit alarm	YES
11	Deviation high limit alarm	NO
02	Deviation low limit alarm	YES
12	Deviation low limit alarm	NO
03	Deviation high / low limit alarm	YES
13	Deviation high / low limit alarm	NO
04 / 14	Deviation high / low limit range alarm	NO
05	Absolute value high limit alarm	YES
15	Absolute value high limit alarm	NO
06	Absolute value low limit alarm	YES
16	Absolute value low limit alarm	NO
07	Segment end alarm (use for program model only)	-
17	Program run alarm (use for program model only)	-
08	System error alarm-on	-
18	System error alarm-off	-
09		-
19	On delay timer alarm	-

Note : the word “**INHIBIT**” means that alarm does not work at the first time.

6.2 Alarm action description

▲ : SV

△ : Alarm set value
(inhibit means alarm doesn't work at the first time)

00 10	Non
01	Deviation high alarm inhibit 
11	Deviation high alarm no inhibit 
02	Deviation low alarm inhibit 
12	Deviation low alarm no inhibit 
03	High low alarm inhibit 
13	High low alarm no inhibit 
04 14	Band alarm 
05	Absolute high alarm inhibit 

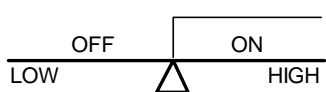
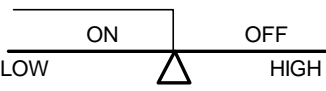
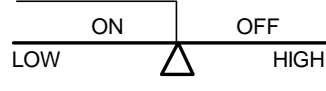
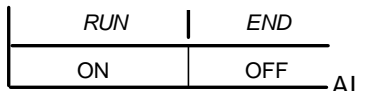
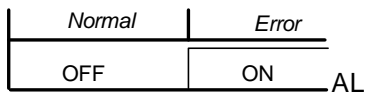
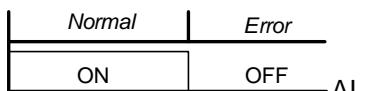
15	Absolute high alarm no inhibit 
06	Absolute low alarm inhibit 
16	Absolute low alarm no inhibit 
07	Segment end alarm (1) ALD1~3 , set 07 (2) AL1~3=alarm segment No.set (3) ALT1~3 if set 0 =flicker alarm ALT1~3 if set 99.59 =continued alarm ALT1~3 if set others =ON delay time
17	Program Run alarm(Refer to SETA.4 , P.22) 
08	System error alarm - ON 
18	System error alarm - OFF 
09	
19	On delay timer When PV=alarm SV , it keeps a certain period(set time)before alarm action. Range:00H.00M~99H.59M

12. Panel cut & Outline Dimension :

12.1 Panel Cut Dimension (Units : mm)

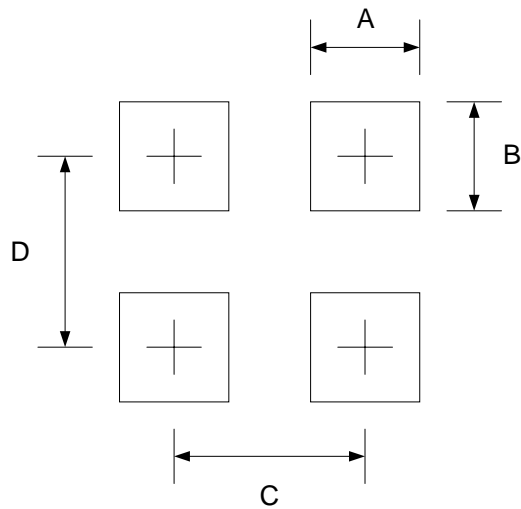

	A	B	C	D
F16	44.5+0.5	44.5+0.5	65	70
F18H	90.5+0.5	44.5+0.5	111	70
F17	68.5+0.5	68.5+0.5	89	94
F18	44.5+0.5	90.5+0.5	65	116
F14	90.5+0.5	90.5+0.5	111	116

12.2 Outline Dimension (Units : mm)

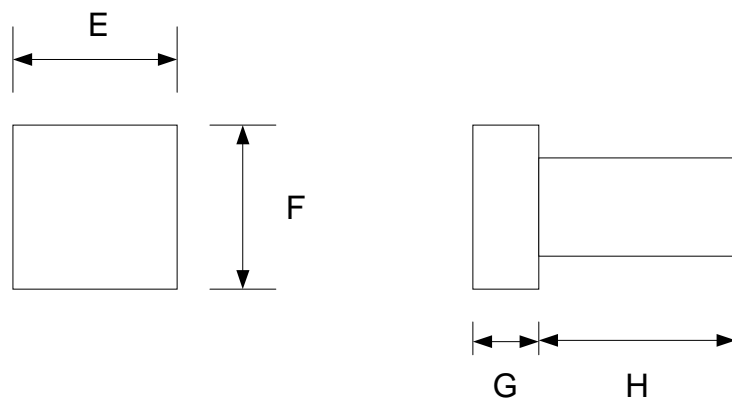

	E	F	G	H
F16	50	50	17	80
F18H	96	50	17	80
F17	74	74	17	80
F18	50	96	17	80
F14	96	96	17	80