

HCS Heaters Controls & Sensors Ltd HCS

60- Meg Dr Unit 13

London Ontario N6E 3T6

Ph (519) 686 2715 Fax (519) 686 8159

FLANGED THERMOWELLS

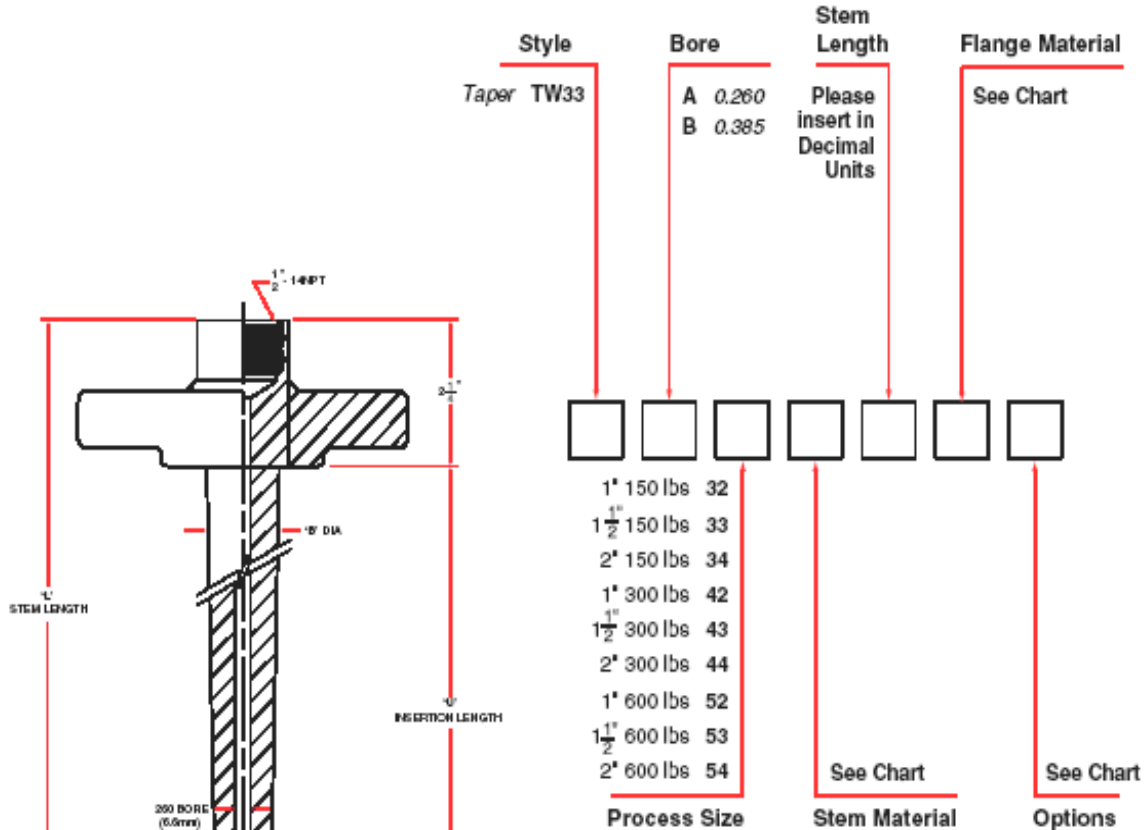

Example:

TW33 Tapered
 A 0.260
 33 1 1/2" 150 lbs
 L 316SS
 06 6" Stem
 B SS Plug & Chain

Material Chart:

- A Brass
- D Carbon Steel
- E A105
- F F11
- G F22
- H 304
- J 304/L
- L 316
- M 316/L
- R Monel
- T Titanium
- U Hast. C

See full chart for more material codes.

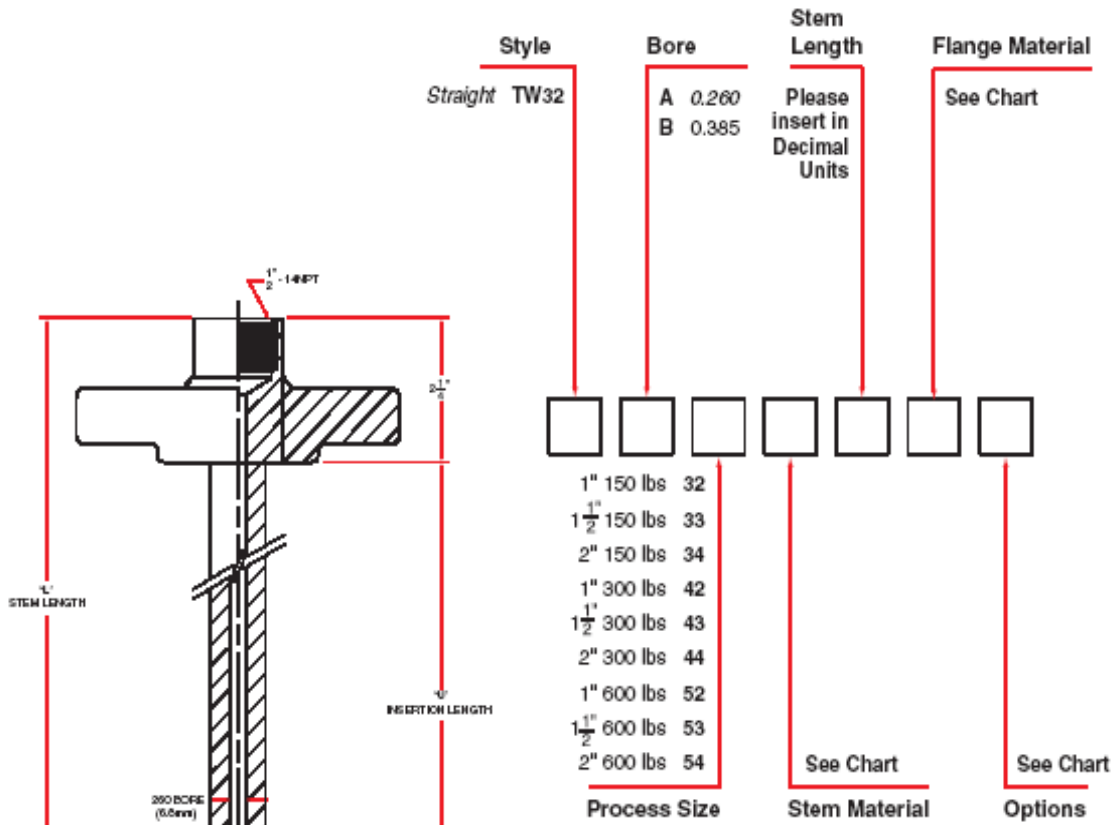

Example:

TW32 Straight
 A 0.260
 33 1 1/2" 150 lbs
 L 316SS
 06 6" Stem
 B SS Plug & Chain

Material Chart:

A Brass
 D Carbon Steel
 E A105
 F F11
 G F22
 H 304
 J 304/L
 L 316
 M 316/L
 R Monel
 T Titanium
 U Hast. C
 See full chart for more material codes.

