

HCS Heaters Controls & Sensors Ltd HCS

60- Meg Dr Unit 13

London Ontario N6E 3T6

Ph (519) 686 2715 Fax (519) 686 8159

THREADED THERMOWELLS

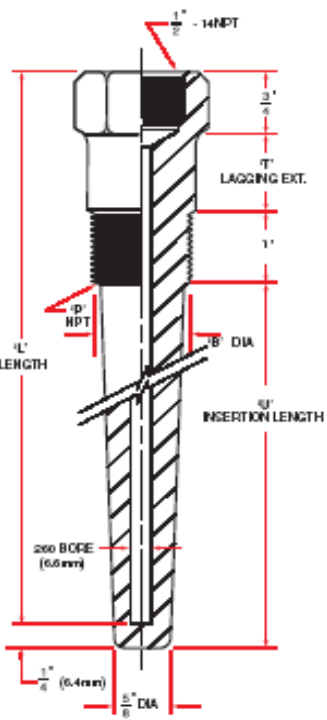

Style	Bore	Stem Length	Options
Taper TW03 Taper-Lag TW13	A 0.260 B 0.385	Please insert in Decimal Units	See Chart
<input type="text"/>	<input type="text"/>	<input type="text"/>	<input type="text"/>
	1/2" NPT 08		
	3/4" NPT 12		
	1" NPT 16		
	1 1/4" NPT 20		
	1 1/2" NPT 24		
	Process Size	Stem Material	

'B' Diameter:

1/2" NPT-	5/8"
3/4" NPT-	7/8"
1" NPT-	1 1/16"

Example:
 TW13 Lagged Tapered
 A 0.260
 12 3/4" NPT
 L 316SS
 08 6" Stem
 T 2" Lag
 B SS Plug & Chain

Material Chart:

A	Brass
D	Carbon Steel
E	A105
F	F11
G	F22
H	304
J	304/L
L	316
M	316/L
R	Monel
T	Titanium
U	Hast. C

See full chart for more material codes.

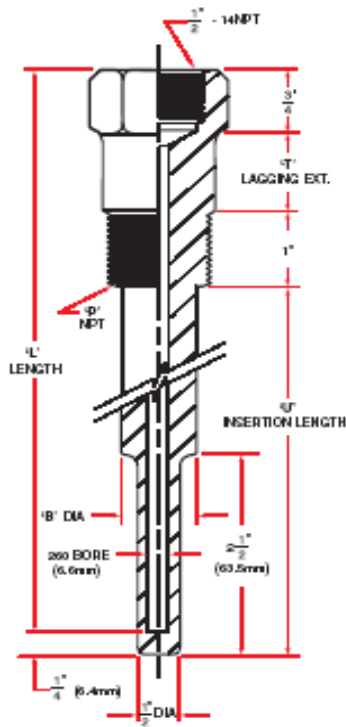

Style
 Stepped TW01
 Stepped Lag TW11

Bore
 A 0.260
 B 0.385

Stem Length
 Please insert in Decimal Units

Options
 See Chart

- 1/2" NPT 08
- 3/4" NPT 12
- 1" NPT 16
- 1 1/4" NPT 20
- 1 1/2" NPT 24

Process Size

See Chart

Stem Material

'B' Diameter:

- 1/2" NPT- 5/8"
- 3/4" NPT- 3/4"
- 1" NPT- 7/8"

Example:

TW11 Lagged Stepped
 A 0.260
 12 3/4" NPT
 L 316SS
 06 6" Stem
 T 2" Lag
 B SS Plug & Chain

Material Chart:

- A Brass
- D Carbon Steel
- E A105
- F F11
- G F22
- H 304
- J 304/L
- L 316
- M 316/L
- R Monel
- T Titanium
- U Hast. C

See full chart for more material codes.

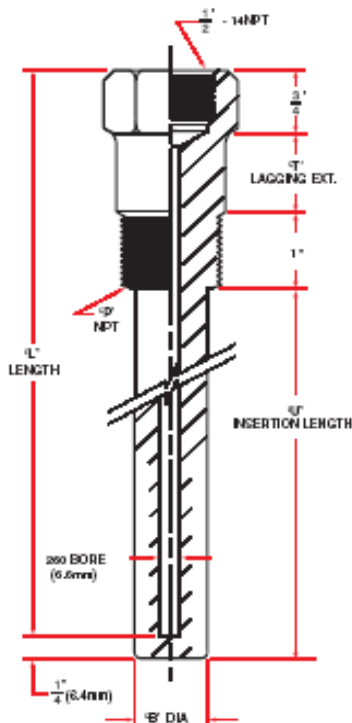

Style	Bore	Stem Length	Options
Straight TW02 Straight Lag TW11	A 0.260 B 0.385	Please insert in Decimal Units	See Chart

<input type="text"/>	<input type="text"/>	<input type="text"/>	<input type="text"/>	<input type="text"/>	<input type="text"/>
----------------------	----------------------	----------------------	----------------------	----------------------	----------------------

- 1/2" NPT 08
- 3/4" NPT 12
- 1" NPT 16
- 1 1/4" NPT 20
- 1 1/2" NPT 24

Process Size

See Chart
Stem Material

'B' Diameter:

- 1/2" NPT- 5/8"
- 3/4" NPT- 3/4"
- 1" NPT- 3/4"

Example:

TW11 Lagged Straight
 A 0.260
 12 3/4" NPT
 L 316SS
 06 6" Stem
 T 2" Lag
 B SS Plug & Chain

Material Chart:

- A Brass
- D Carbon Steel
- E A105
- F F11
- G F22
- H 304
- J 304/L
- L 316
- M 316/L
- R Monel
- T Titanium
- U Hast. C

See full chart for more material codes.